

ESEMPI APPLICATIVI DEL CALCESTRUZZO FIBRORINFORZATO NEL RINFORZO STRUTTURALE

PESARO, 16 Maggio 2014

Francesca Simonelli



TECNOCHEM[®]
I T A L I A N A S P A

Normativa di riferimento: uso nella riparazione e nel rinforzo

DM 14 gennaio 2008

8.6 Materiali

Gli interventi sulle strutture esistenti devono essere effettuati con i materiali previsti dalle presenti norme; possono altresì essere utilizzati materiali non tradizionali purché nel rispetto di normative e documenti di comprovata validità, ovvero quelli elencati al cap.12

CNR DT204 2006 Istruzioni per la Progettazione, l'Esecuzione ed il Controllo di Strutture di Calcestruzzo Fibrorinforzato



A26 Novi Ovada: Viadotto di attraversamento dell'Orba



Intervento previsto sul tratto della A26 in prossimità di Ovada, attraversamento del torrente Orba

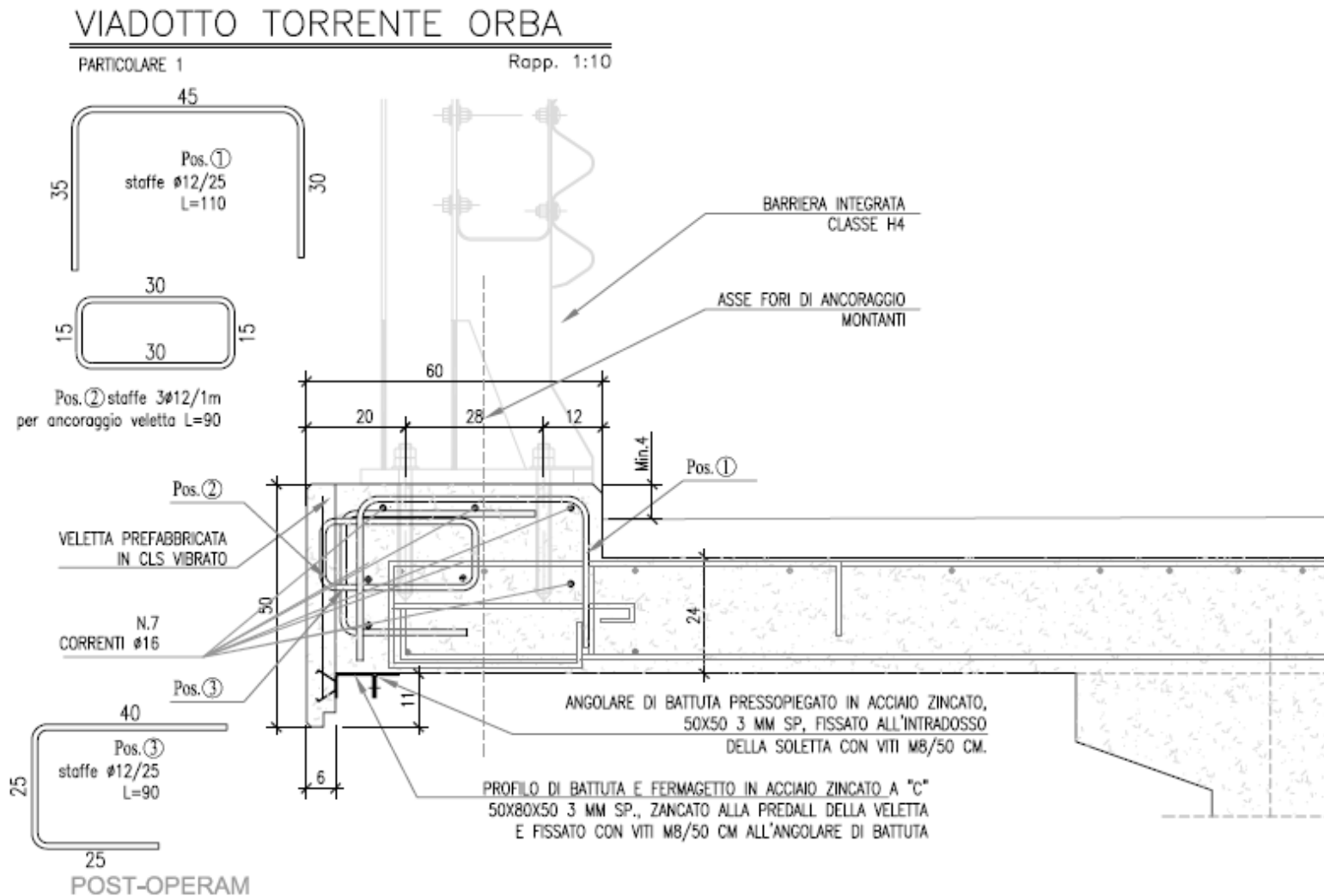

INTERVENTO ALTERNATIVO PROPOSTO

VIADOTTO TORRENTE ORBA

PARTICOLARE 1

Rapp. 1:10

Comportamento a trazione del materiale è di tipo incrudente
(CNR-DT 204-2006)



POST-OPERAM



CARATTERISTICHE DEL CALCESTRUZZO FIBRORINFORZARO DI PROGETTO

Classe di resistenza C 70/85

ftk = 4 mm

Classe di consistenza S5

Diametro massimo 12 mm

CARATTERISTICHE DI QUALIFICA DEL CALCESTRUZZO FIBRORINFORZARO

Classe di resistenza > C 70/85

ftk > 4 mm (60 kg/mc)

Classe di consistenza S5

Diametro massimo 8 mm



QUALIFICA DEL MATERIALE: RESISTENZA A COMPRESSIONE

SIGL A	DATA GETTO	DATA PROVA	Rc 28 gg	Rc 7 gg	Rc 3 gg	Densità a fresco	Fluidità
			MPa	MPa	MPa	g/l	mm
1	16/10/12	21/11/12	101,8	81,3	52,1	2513	500
2	16/10/12	21/11/12	98,5	78,7	51,5	2497	520
3	22/10/12	21/11/12	102,8	78,2	64,8	2474	480
4	22/10/12	21/11/12	105,3	73	67	2470	500
5	29/10/12	27/11/12	103,6	76	63,2	2482	510
6	11/12/12	08/01/12	102	71,3	53,3	2480	550

$$R_{cm} = 102.33 \text{ MPa} \quad \longrightarrow \quad R_{ck} = 94.33 \text{ MPa}$$



QUALIFICA DEL MATERIALE: PROVA A FLESSIONE

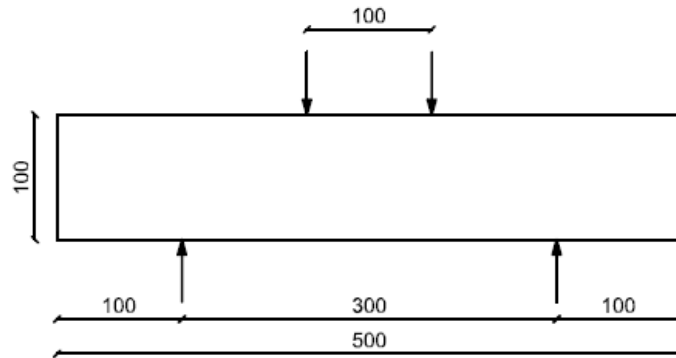

SIGLA	DATA GETTO	DATA PROVA	P_{max}	P_{lf}	f_{max}	f_{lf}	$f_{t,max}$	$f_{t,lf}$
			[kN]	[kN]	[N/mm ²]	[N/mm ²]	[N/mm ²]	[N/mm ²]
1	16/10/12	21/11/12	42.74	25.08	12.82	7.52	8.56	5.02
2	16/10/12	21/11/12	37.84	25.57	11.35	7.67	7.58	5.12
3	22/10/12	21/11/12	44.39	29.52	13.32	8.86	8.89	5.91
4	22/10/12	21/11/12	39.94	26.39	11.98	7.92	8.00	5.29
5	29/10/12	27/11/12	41.71	22.85	12.51	6.86	8.36	4.58
6	11/12/12	08/01/12	48.58	23.63	14.58	7.08	9.73	4.73



QUALIFICA DEL MATERIALE: PROVA A FLESSIONE

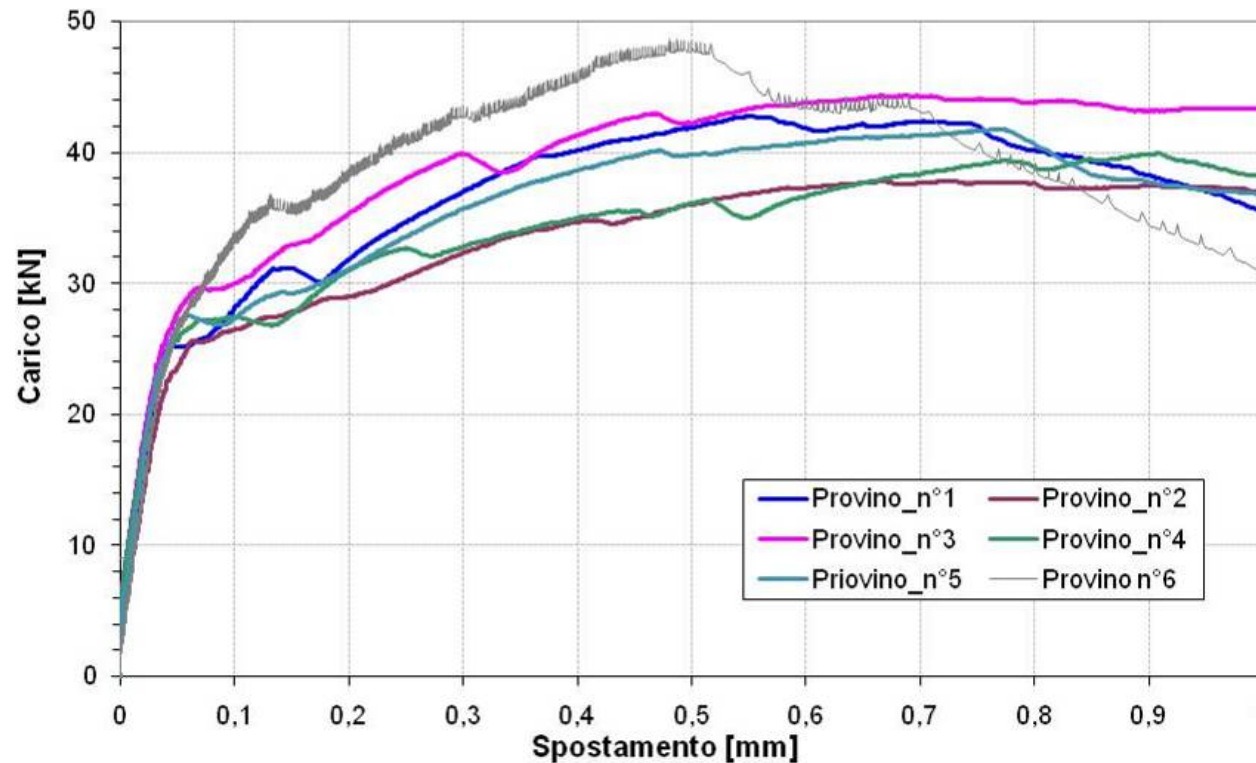

$$f_{tm} = 5.11 \text{ MPa} \quad \longrightarrow \quad f_{tk} = 4.61 \text{ MPa}$$



SPERIMENTAZIONE IN LABORATORIO



SPERIMENTAZIONE IN LABORATORIO

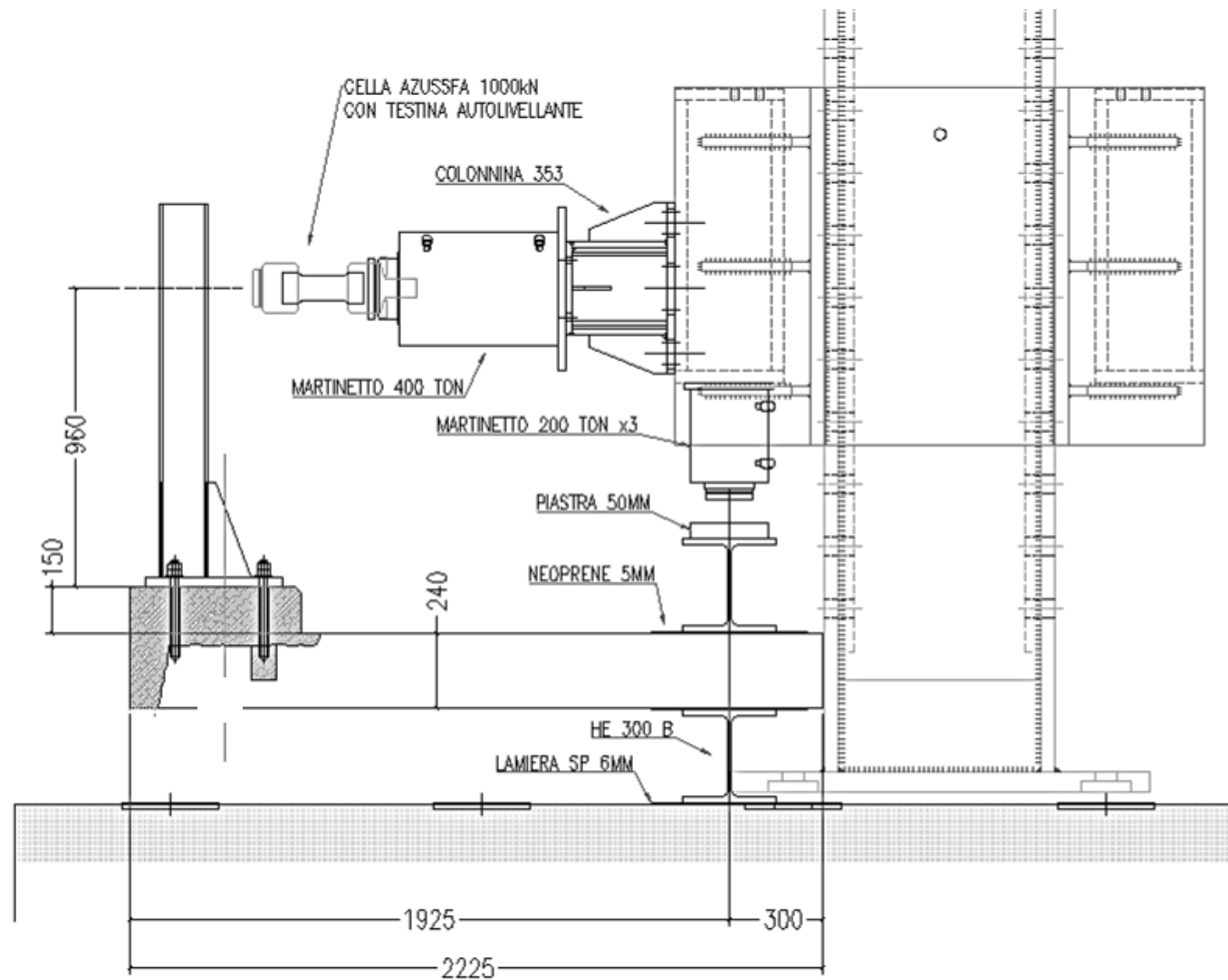

SPERIMENTAZIONE IN LABORATORIO

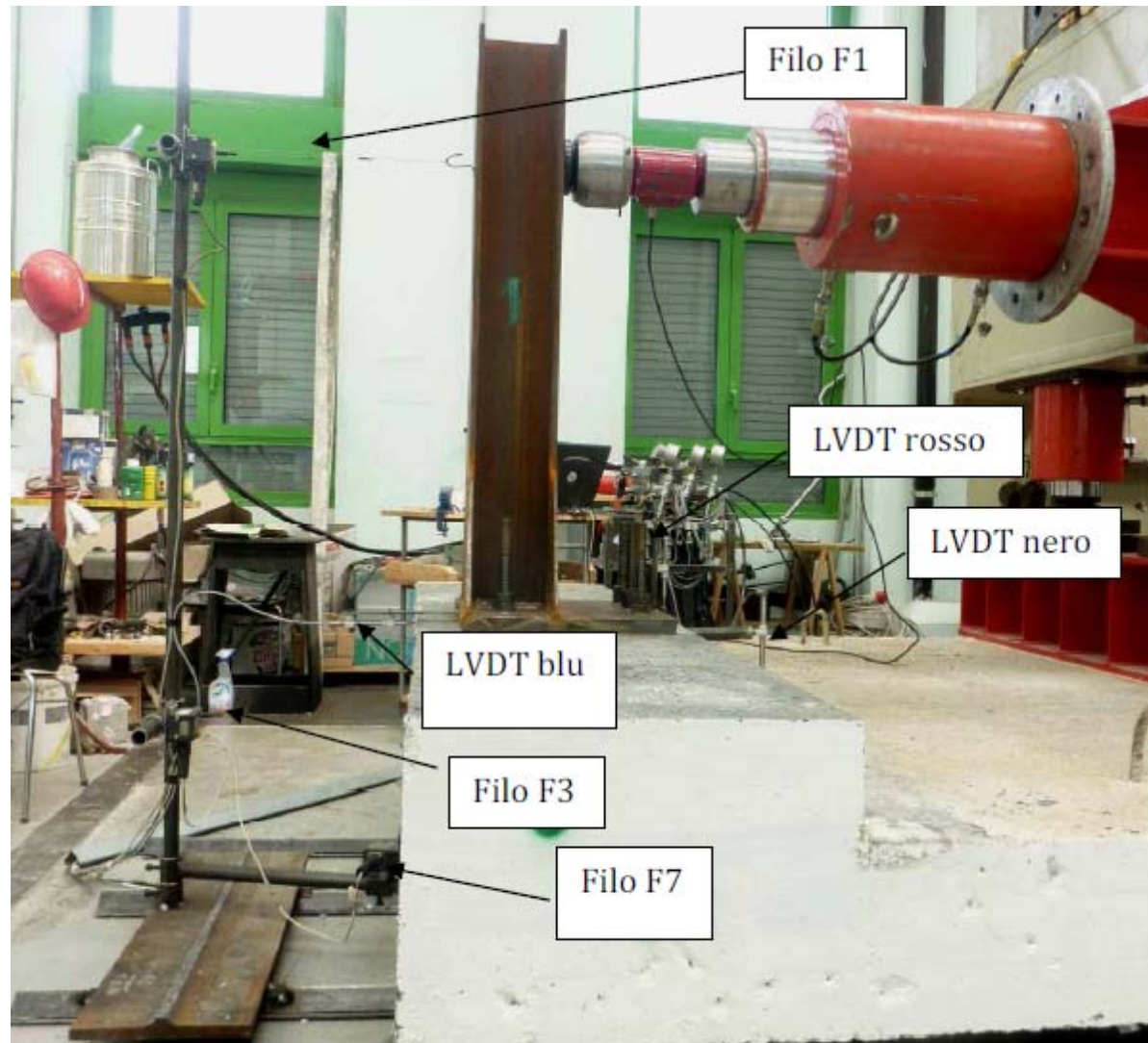

SPERIMENTAZIONE IN LABORATORIO



CARICO MASSIMO RAGGIUNTO (I PROVA): 106 KN
CARICO MASSIMO RAGGIUNTO (II PROVA): 103 KN



SPERIMENTAZIONE SU SCALA REALE PRESSO L'UNIVERSITA' DI ROMA 2

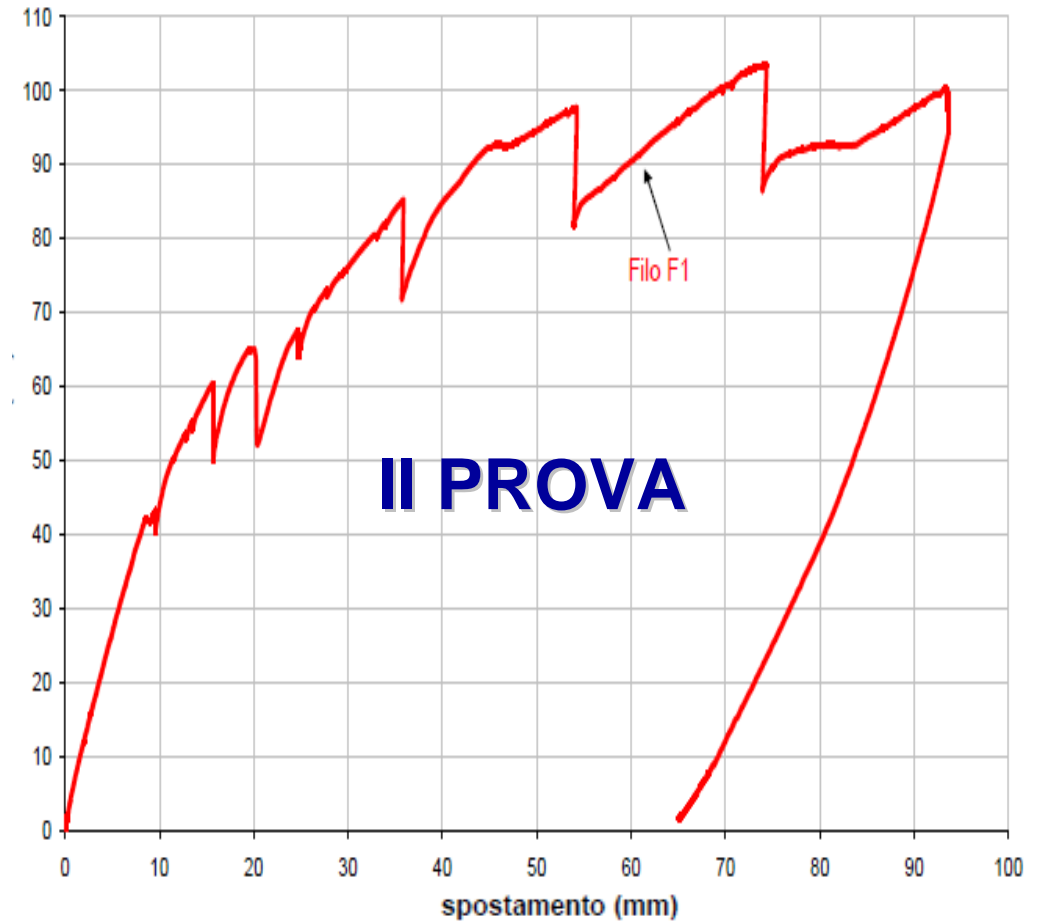
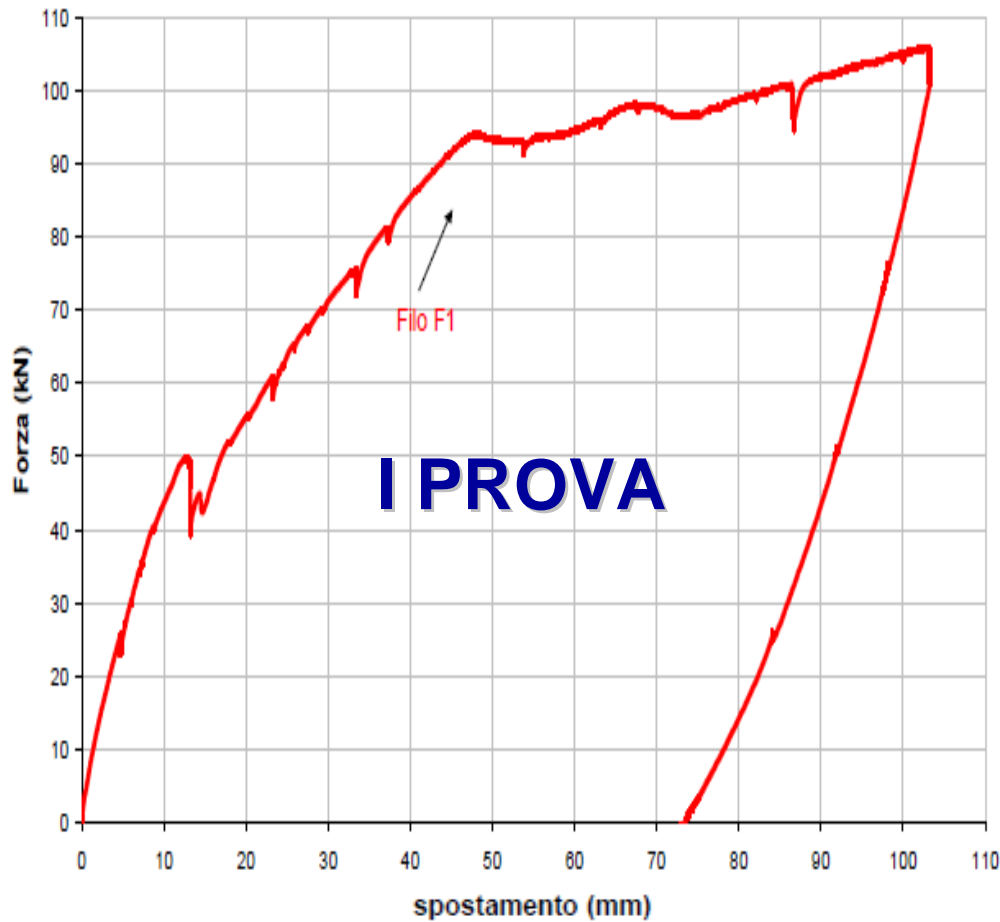

FASI REALIZZATIVE: preparazione del supporto



FASI REALIZZATIVE: getto



FASI REALIZZATIVE: fratazzatura



FASI REALIZZATIVE: stagionatura



FASI REALIZZATIVE: foratura cordolo



FASI REALIZZATIVE: montaggio della barriera



VERIFICHE ESEGUITE IN FASE DI ESECUZIONE:

DM 14.01.2008:

“Per produzioni di calcestruzzo inferiori ai 1500 mc di miscela omogenea, effettuate direttamente in cantiere, mediante processi di produzione temporanei e non industrializzati, deve essere confezionata sotto la diretta responsabilità del costruttore.”

Circolare n. 617

“Nei cantieri di opere che prevedono una quantità di calcestruzzo inferiore a 1500 mc, restano nella responsabilità del costruttore e del direttore lavori, ciascuno per le proprie competenze, tutte le procedure di confezionamento e messa in opera del calcestruzzo.”



VERIFICHE ESEGUITE IN FASE DI ESECUZIONE:

Allo stato fresco:

- Misura dello slump
- Misura della massa volumica allo stato fresco
- Misura dell'umidità degli aggregati
- Verifica visiva della corretta miscelazione (tabella 8-1 DT 204/2006, con frequenza gionaliera)

Allo stato indurito:

- Resistenza a compressione a 24 h, 2gg, 3gg, 7gg, 14 gg, 28 gg
- Resistenza a flessotrazione A 7gg, 14gg, 28gg (la frequenza minima di campionatura è la stessa dei prelievi per le prove di accettazione)
- Valutazione del contenuto di fibre



RISULTATI DELLE PROVE ESEGUITE DAL LABORATORIO UFFICIALE (SLUMP E DELL'UMIDITA' DEGLI INERTI, 1° gg di getto)

Mix	Data (ora) Impasto	Misure allo stato fresco			Umidità				Valor medio (%)
		Temperatura aria / Cls °C	Slump-test (UNI EN 12350/2) (cm)	Slump-flow (UNI EN 11041) (cm)	Big-bag				
					43 (%)	22A (%)	B (%)	EM (%)	
REFOR-tec ^R GF100/ST- HS - betoncino	16/10/2012 (ore 12:30)	17 / 21	25,5	48,0	4,7	5,0	3,9	3,9	4,4
Mix	Cemento + additivi ed aggiunte in polvere (leg) (kg/m ³)	Aggregato D _{max} 10 mm (kg/m ³)	Fibre FIB-energy ^R 0,30x35 (kg)	Additivo liquido (kg)	Massa volumica		Acqua		Rapporto a _e /leg
					M _{v1} : teorica senza acqua aggiunta (kg/m ³)	M _{v2} : misurata con acqua aggiunta (kg/m ³)	aggiunta: M _{v1} -M _{v2} (kg/m ³)	efficace (a _e)** (kg/m ³)	
REFOR-tec ^R GF100/ST- HS - betoncino	780	1500 *	60	17,2	2357,2	2495	137,8	176,8	0,23



RISULTATI DELLE PROVE ESEGUITE DAL LABORATORIO UFFICIALE

(MISURA DEL CONTENUTO DI FIBRE, 1° gg di getto)

SIGLA PROVINO	DATA PROVA	TIPO PROVA	MASSA PROVINO (kg)	MASSA VOLUMICA (kg/m ³)	Fibre estratte dal provino (g)	Dosaggio fibre in cls indurito (kg/m ³)	
1A	17/10/12	valutazione del contenuto di fibre su cubetti rotti a compressione frantumati e setacciati	2,495	2448	62,2	61,0	60,5
1B			2,506	2451	59,7	58,4	
1C			2,504	2459	63,1	61,9	
4A			2,492	2433	61,9	60,4	60,1
4B			2,506	2433	60,4	58,6	
4C			2,510	2442	62,8	61,1	



RISULTATI DELLE PROVE ESEGUITE DAL LABORATORIO UFFICIALE (RESISTENZA A COMPRESSIONE, 1° gg di getto)

SIGLA PROVINO	DATA PROVA	TIPO PROVA E NORMATIVA DI RIFERIMENTO	MASSA PROVINO (kg)	MASSA VOLUMICA (kg/m ³)	CARICO DI ROTTURA (kN)	AREA CARICATA (AxB) (mm ²)	R _c (N/mm ²)	R _{cmedia} (N/mm ²)
1	17/10/12	Resistenza a compressione (UNI EN 12390/3) e Massa volumica (UNI EN 12390/7)	8,315	2447	836	22650	36,9	37,5
2	(1g)		8,270	2450	857	22500	38,1	
3	18/10/12		8,310	2462	1291	22500	57,4	56,9
4	(2gg)		8,354	2475	1270	22500	56,4	
5	19/10/12		8,253	2445	1371	22500	60,9	61,2
6	(3gg)		8,270	2450	1381	22500	61,4	
7	23/10/12		8,328	2451	1650	22650	72,8	73,5
8	(7gg)		8,294	2441	1680	22650	74,2	
9	30/10/12		8,364	2478	2019	22500	89,7	88,6
10	(14gg)		8,309	2462	1967	22500	87,4	
11	13/11/12		8,364	2462	2070	22650	91,4	93,0
12	(28gg)		8,314	2447	2141	22650	94,5	



RISULTATI DELLE PROVE ESEGUITE DAL LABORATORIO UFFICIALE (VALUTAZIONE DEL COMPORTAMENTO INCRUDENTE)

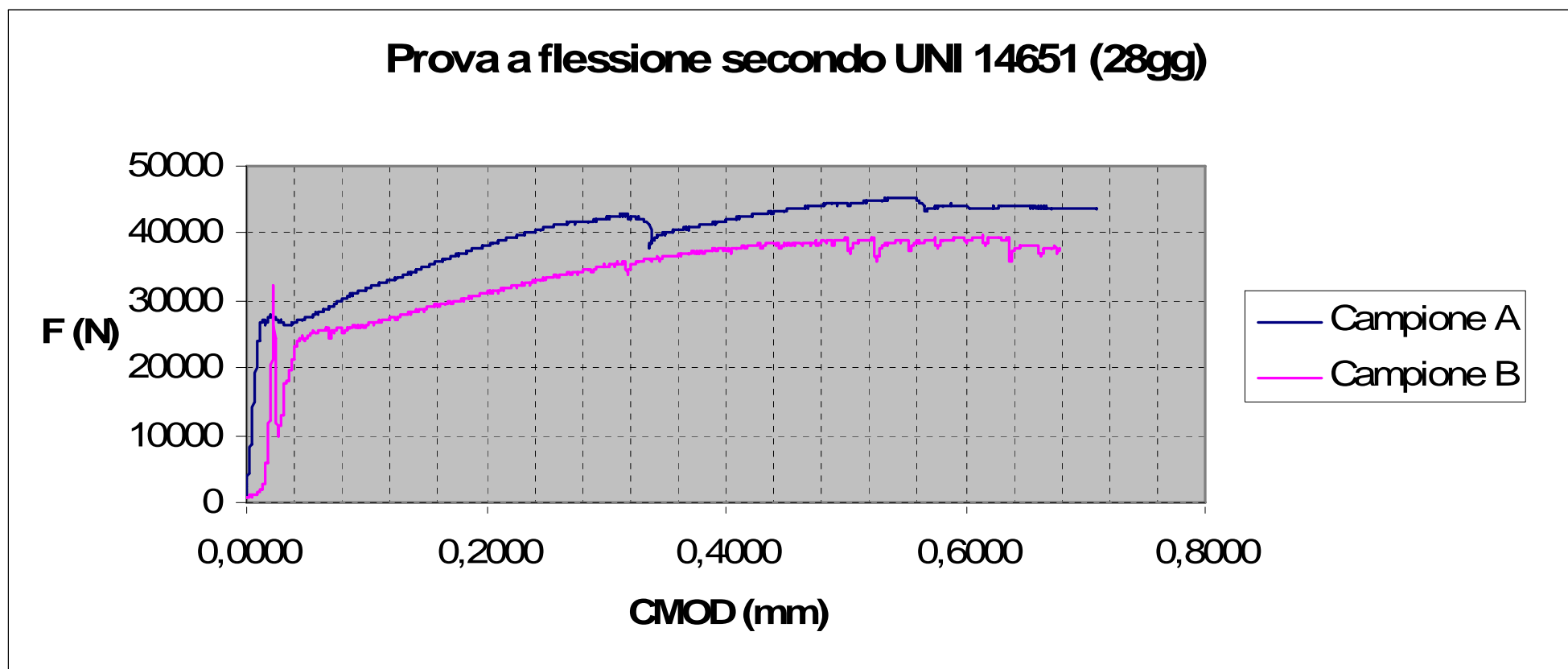

Punching shear in bridge deck

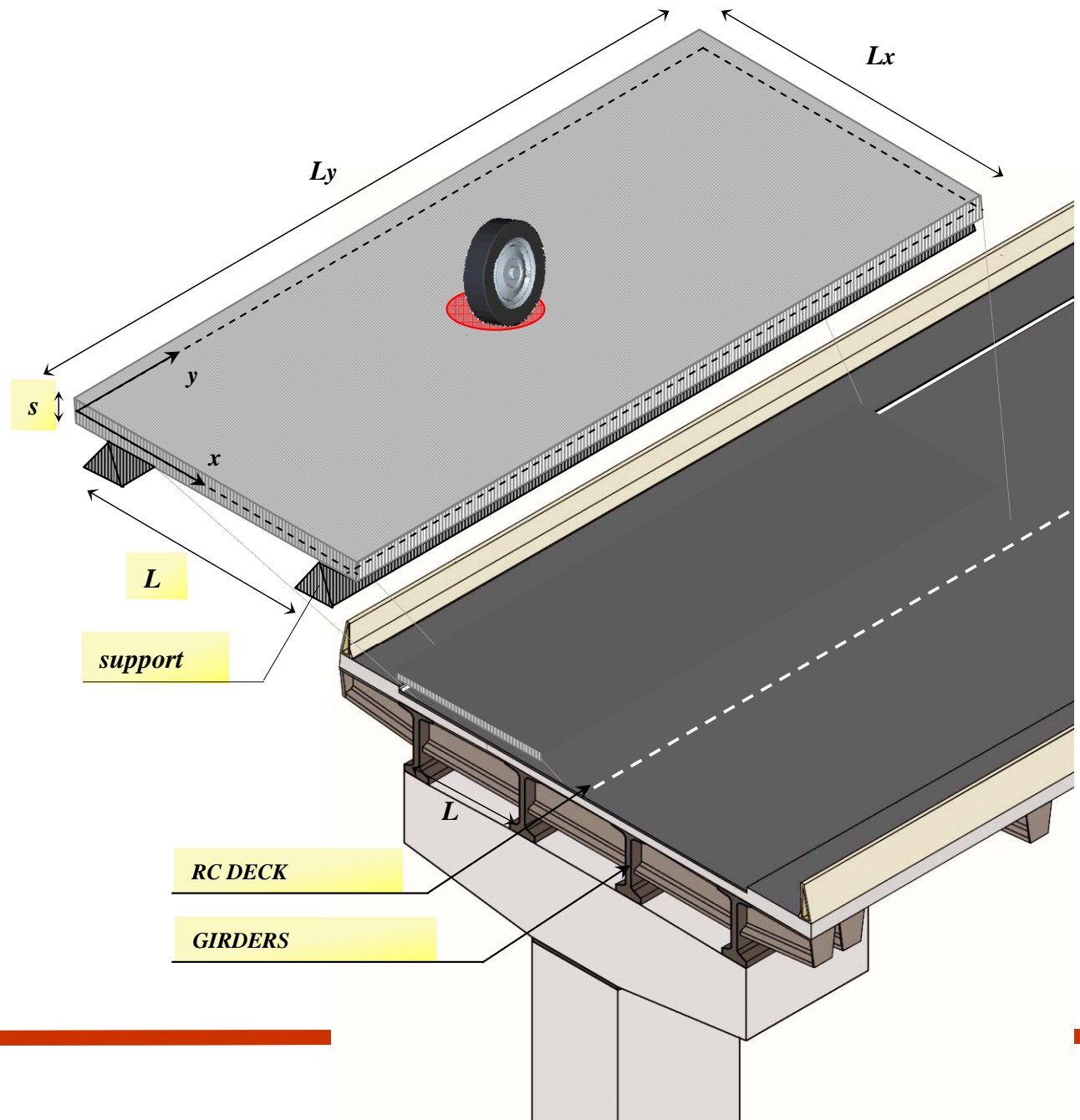
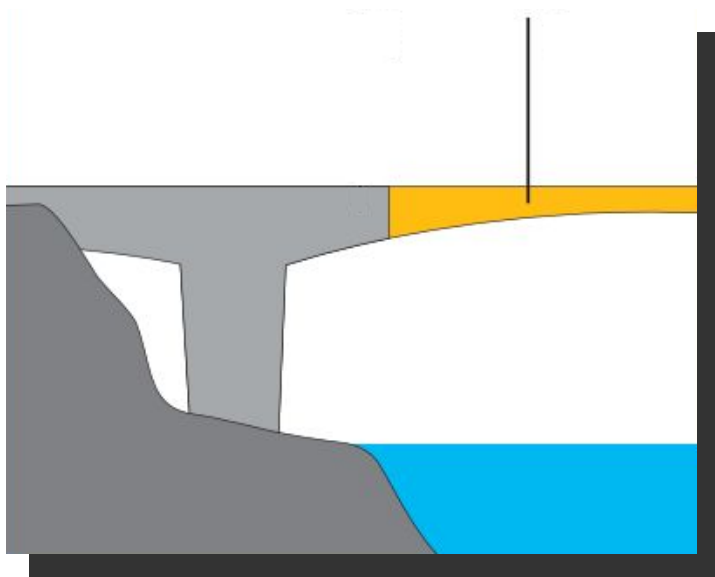

Punching shear in bridge deck

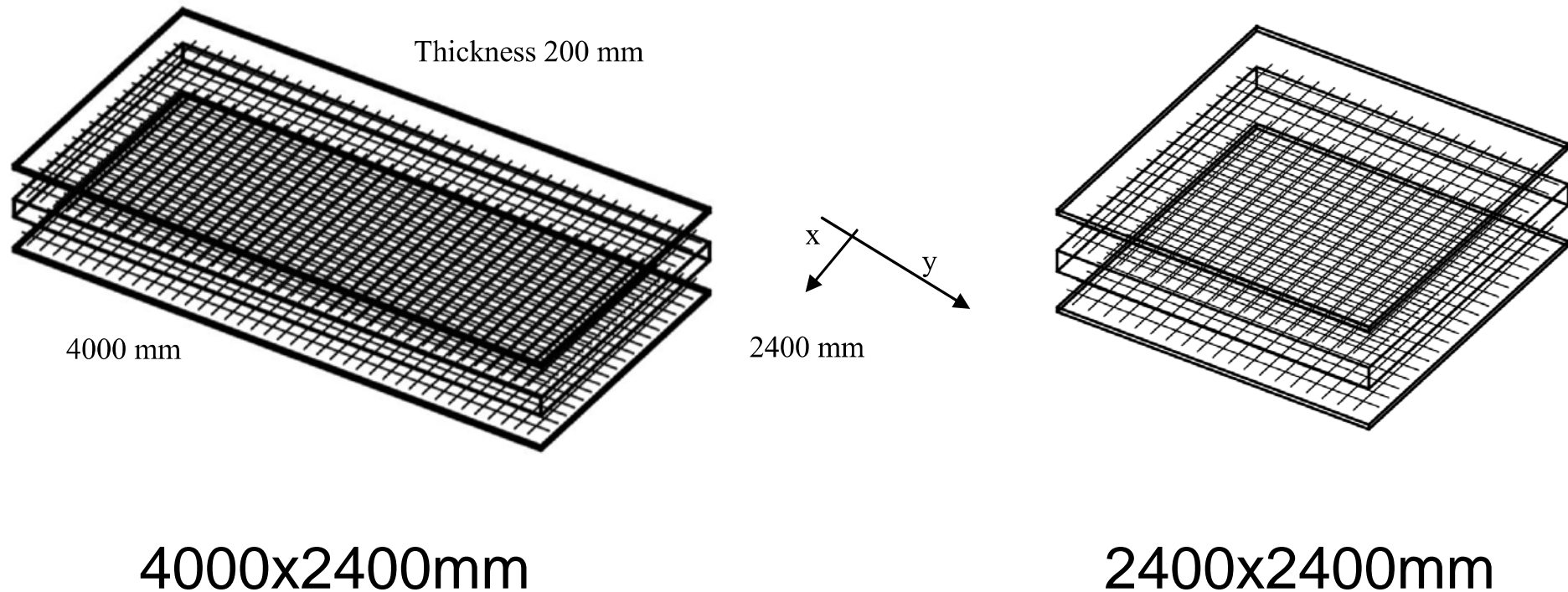

Grimaldi, A., Meda, A., Rinaldi, Z. Experimental behaviour of fibre reinforced concrete bridge decks subjected to punching shear. Composites Part B: Engineering 2013



Risultati piastre quadrate

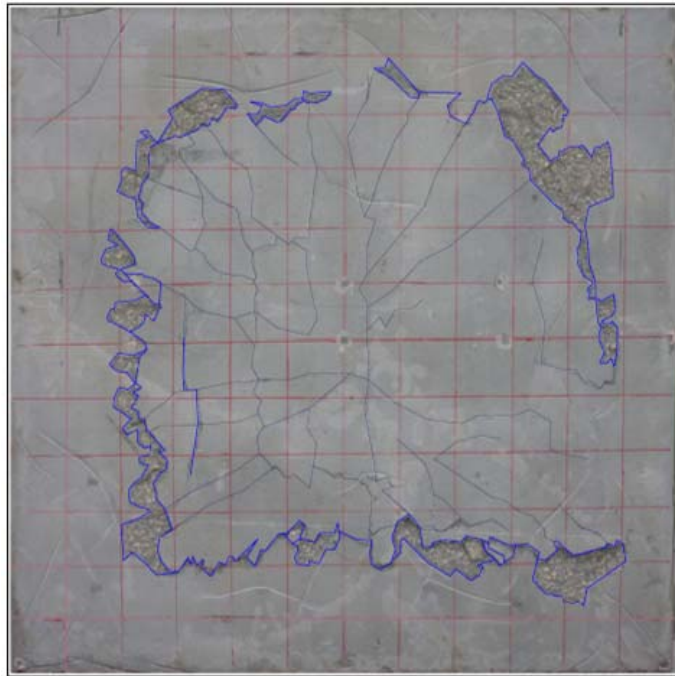

Superficie di rottura

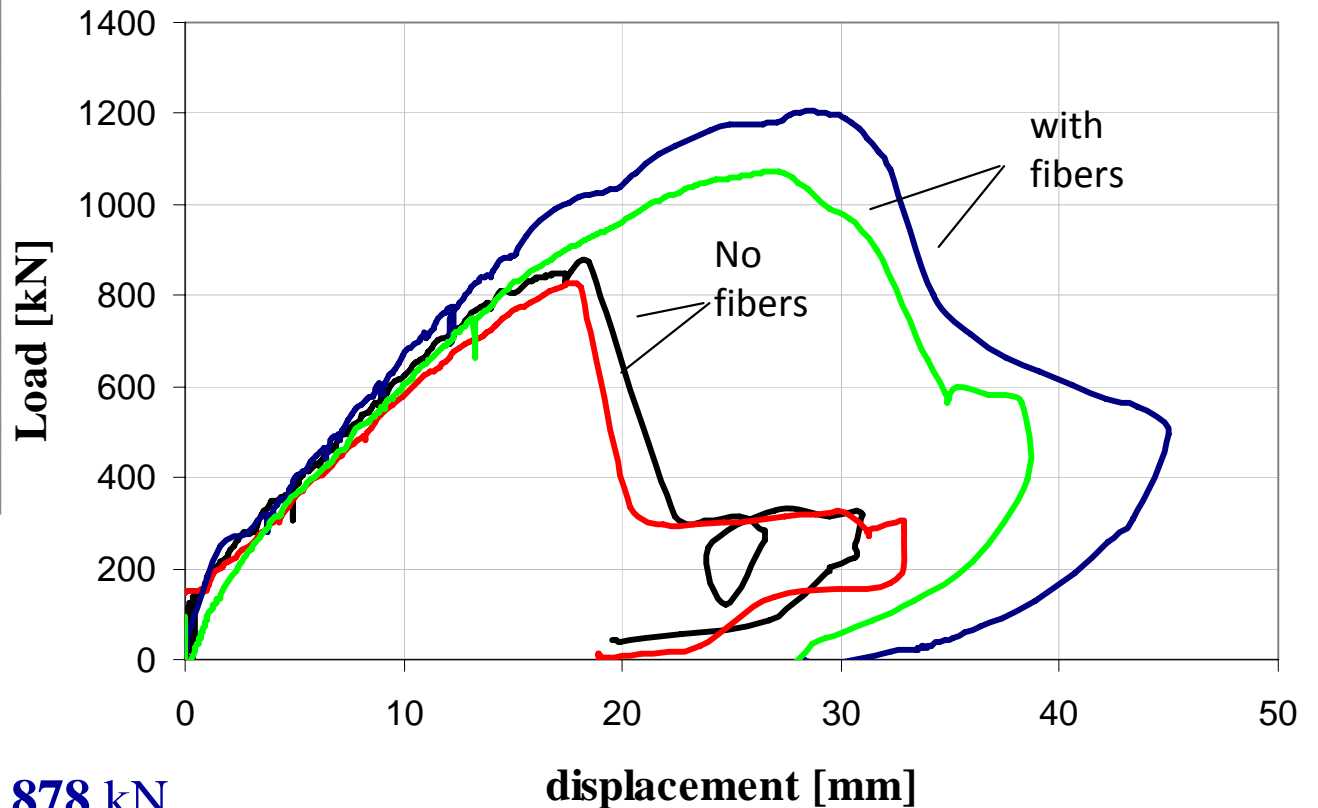

Carico picco piastre c.a: **828 kN, 878 kN**

Carico picco piastre SFRC: **1074 kN, 1205 kN**

Incremento di resistenza: 34%



Risultati piastre rettangolari

Prime fessure: flessionali



Carico centrato:
rottura a punzonamento

Volume fibre = 0.5%

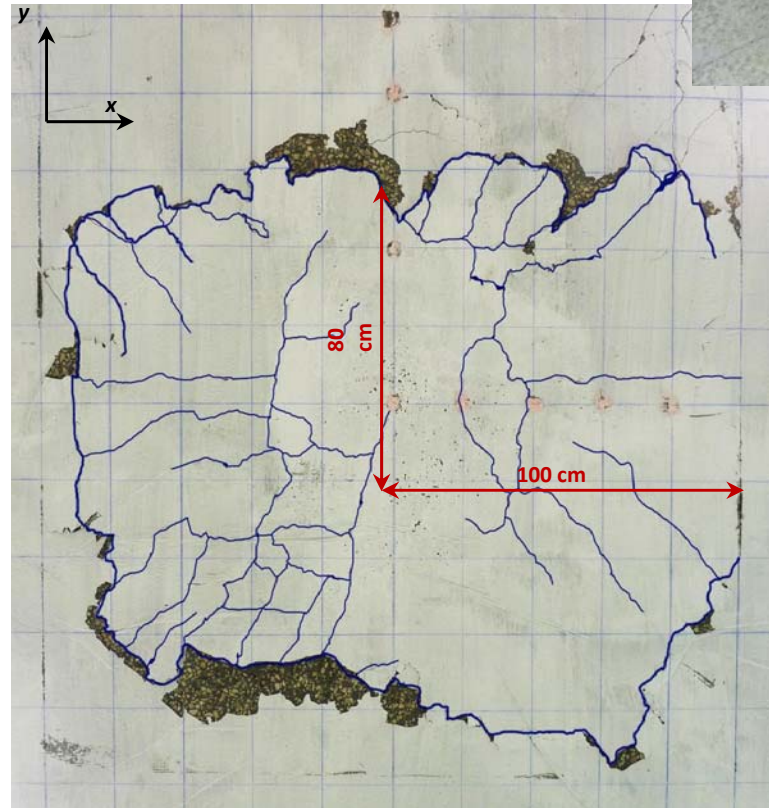

Risultati piastre rettangolari

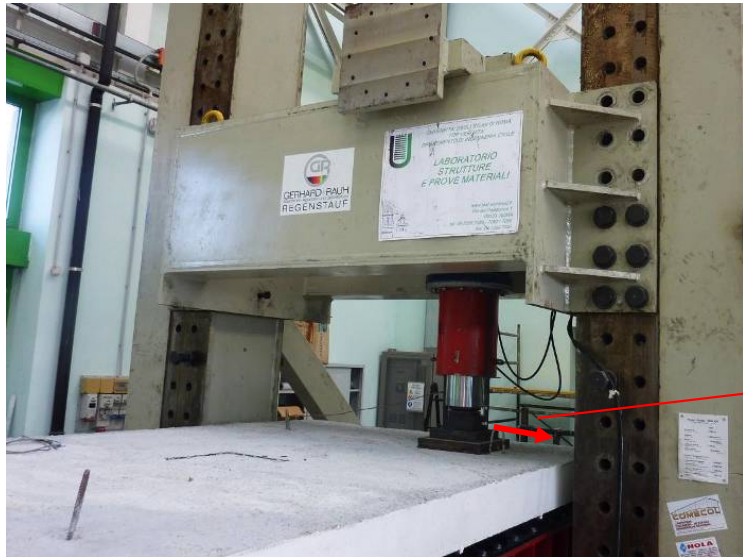

Carico laterale:
rottura a taglio

50 cm

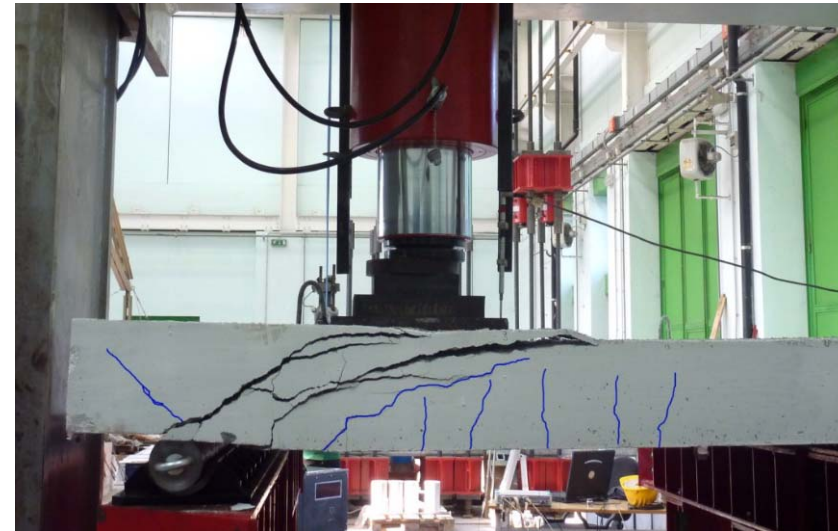
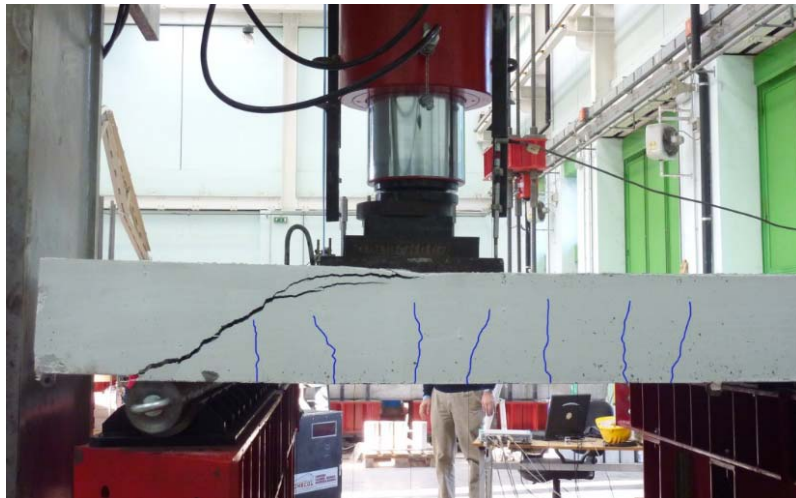
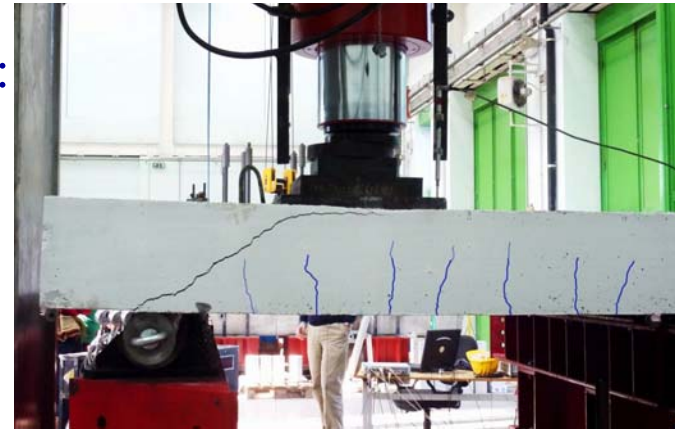

Mix Design

- REF** reference concrete, normal weight
- USW** lightweight concrete with Urban Solid Waste ashes
- USW-FRC** lightweight concrete with Urban Solid Waste ashes and steel fibers.

	REF	USW	USW-FRC
Cement II A/LL 42.5 R	453	472	460
USW ashes {1}	-	140	133
Sand 0-6 mm	986	922	1113
Gravel 2-16 mm	678	165	-
Expanded clay	-	344	295
Water	171	170	162
Plasticizers	16	38	48.1
Expansive additive	29	32.3	32
Fiber	-	-	30

{1} in Slurry, dry content 40%



Results

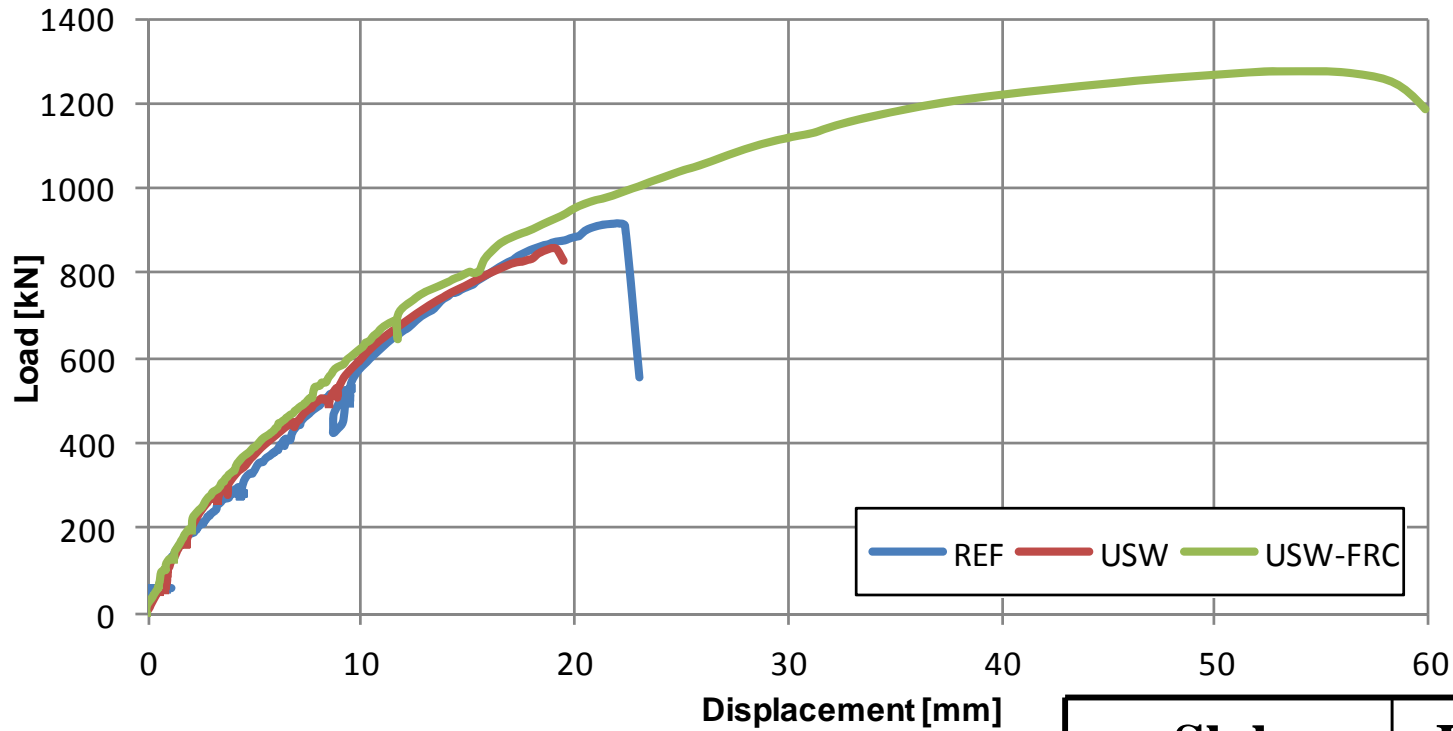

Slab	Punching load	
REF	914 kN	1
USW	862 kN	0.94
USW-FRC	1277 kN	1.40



Results

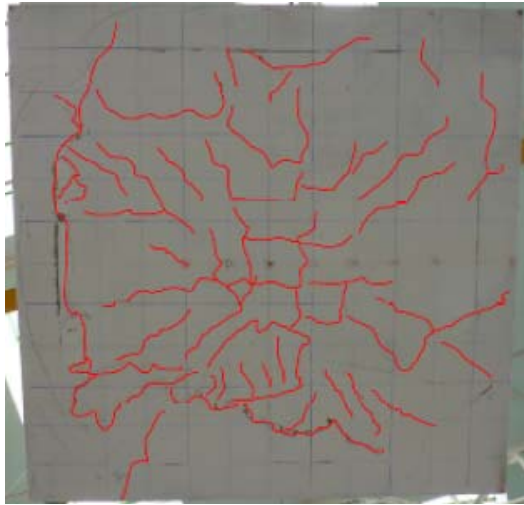

REF

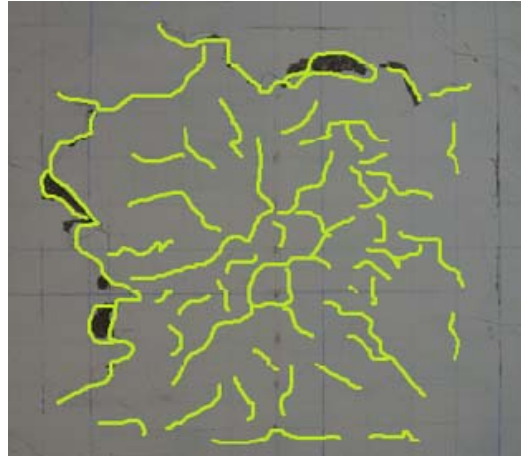

USW

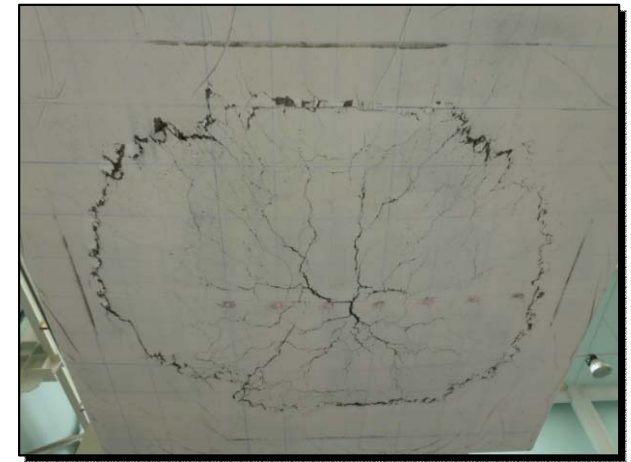

USW-REF

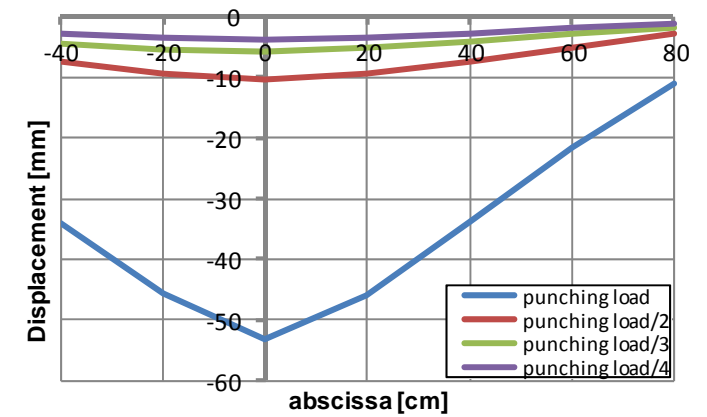
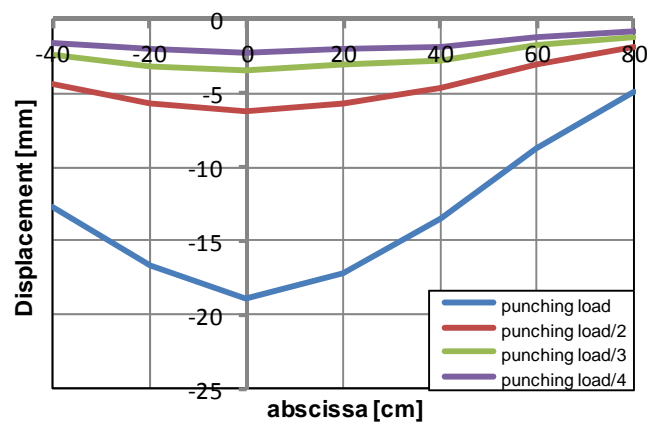
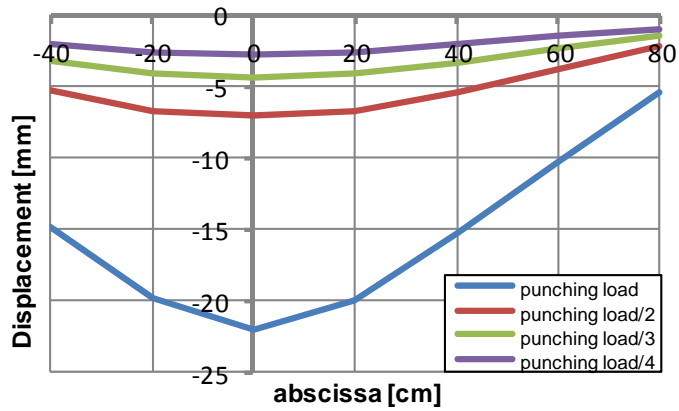

SCUOLA ELEMENTARE DE AMICIS (ROMA)

- Dati di partenza:

- struttura in calcestruzzo armato;
- un piano seminterrato ed un piano fuori terra;
- comune classificato a rischio sismico (ex zona 2);



- Richiesta:

- vulnerabilità sismica
- progetto di adeguamento sismico

RINFORZO DI PILASTRI





Figura 1. Scuola elementare "De Amicis" sita in comune di Zagarolo, oggetto dell'intervento.



PROGETTO DI ADEGUAMENTO SISMICO

- **RINGROSSO DEI PILASTRI MEDIANTE CALCESTRUZZO FIBRO-RINFORZATO CON FIBRE DI ACCIAIO (L=12mm)**
- **RINFORZO DELLE TRAVI MEDIANTE TESSUTI IN FIBRE DI CARBONIO**

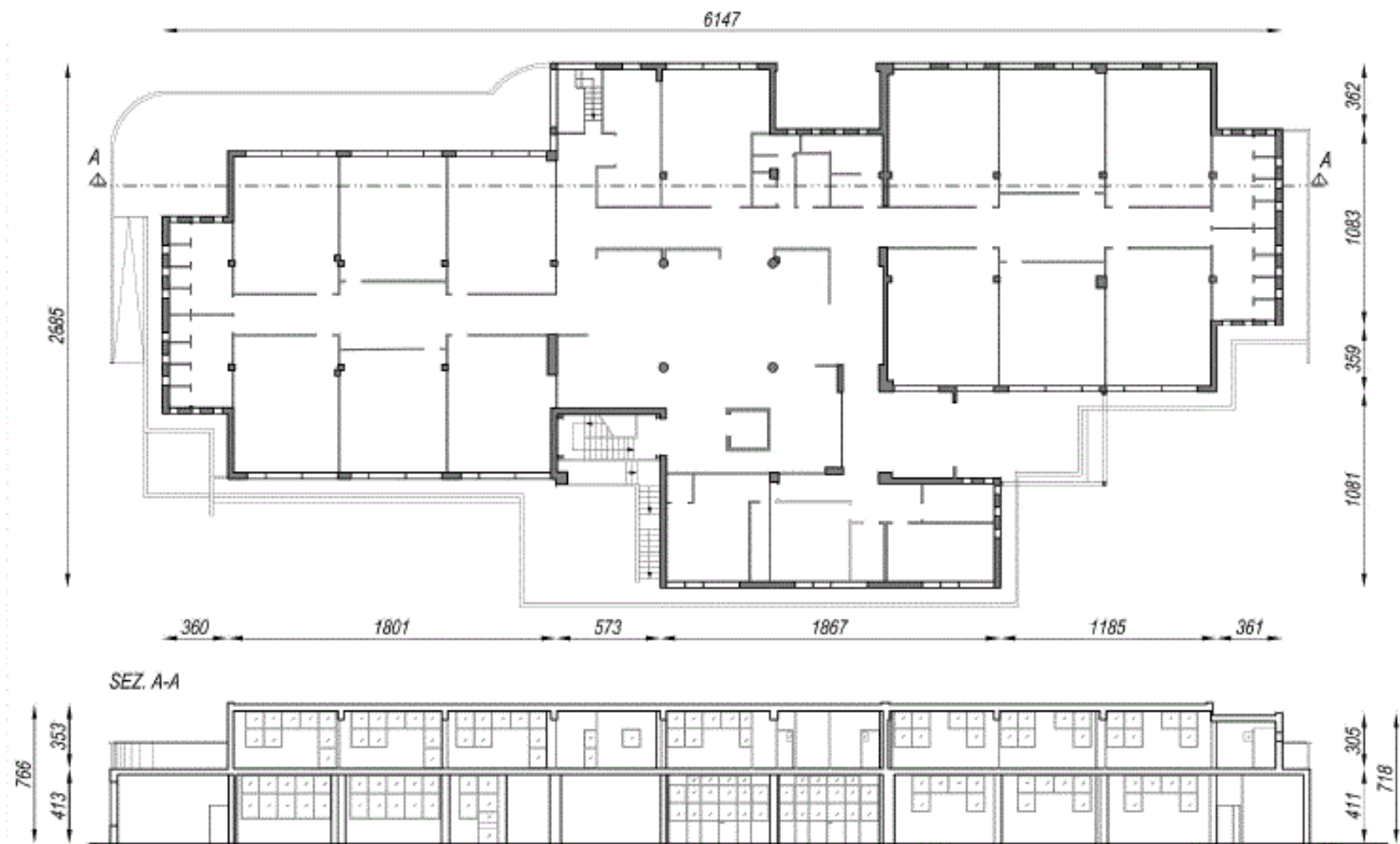
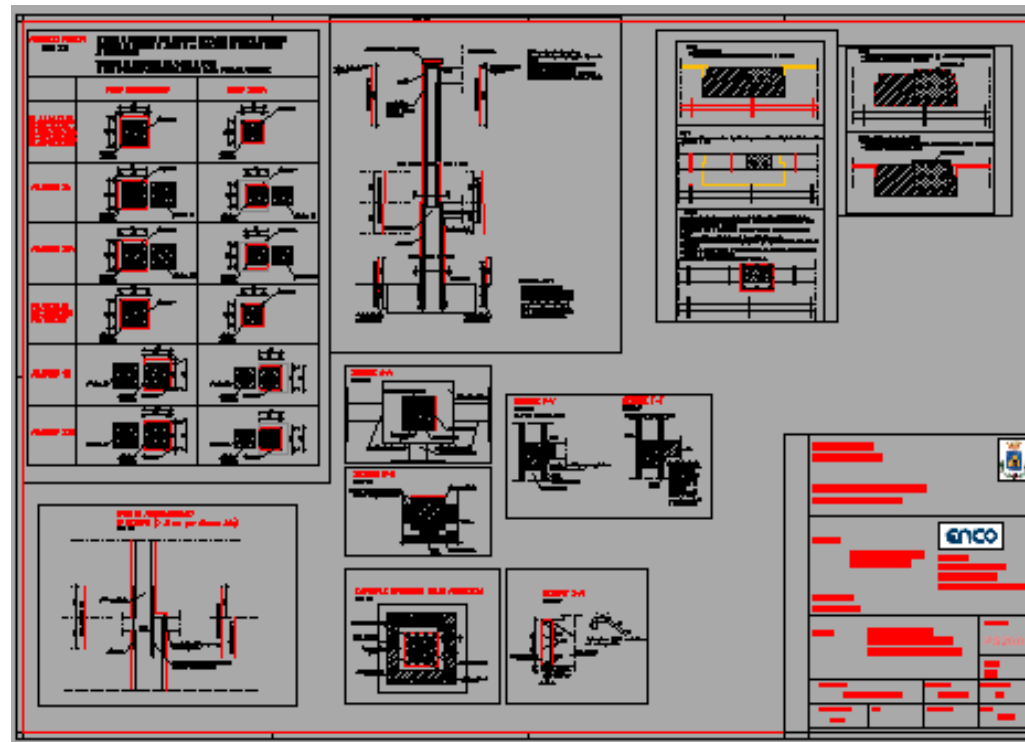

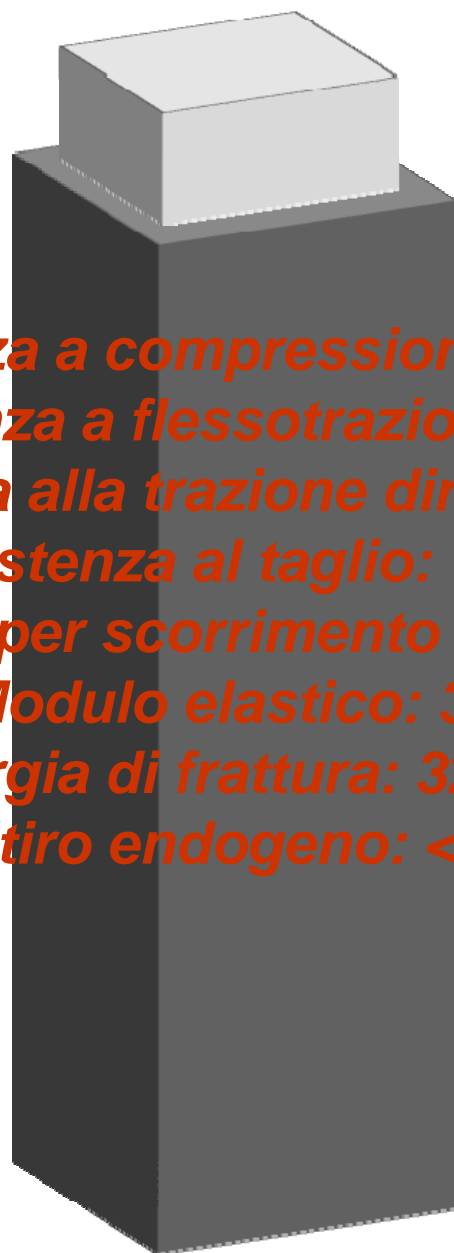

Resistenza a compressione: 130 N/mm²

Resistenza a flessotrazione: 32 N/mm²

Resistenza alla trazione diretta: 8,5 N/mm²

Resistenza al taglio: 16 N/mm²

Resistenza al taglio per scorrimento sull'interfaccia: 4 N/mm²

Modulo elastico: 38 GPa

Energia di frattura: 32.500 N/m

Ritiro endogeno: < 0,05 %



Prove di trazione (CNR-DT 204-2006)

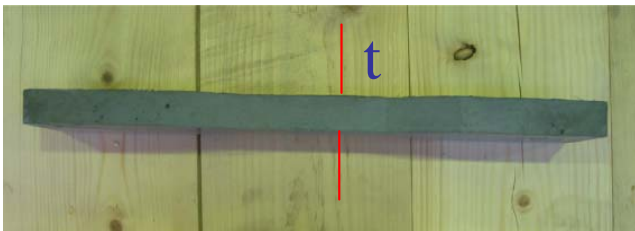
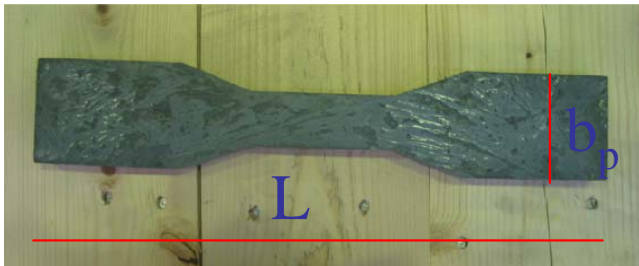

$L = 330 \text{ mm}$

$t = 13 \text{ mm}$

$b_p = 30 \text{ mm}$

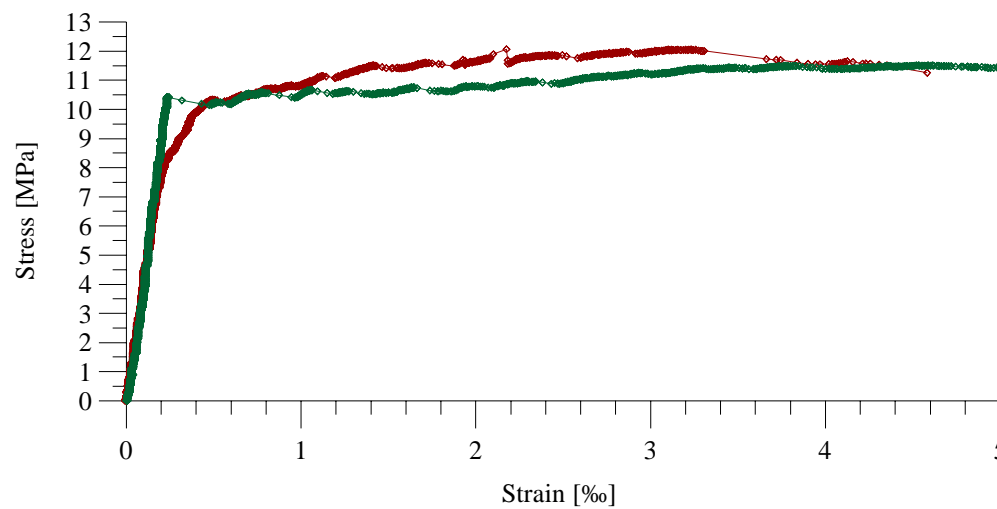



- ✓ Travette 150x150x600 mm
- ✓ Sabbatura della superficie
- ✓ Applicazione 40 mm di rinforzo
- ✓ Prove a flessione su 4 punti

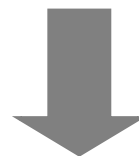

Perfetta aderenza tra i materiali

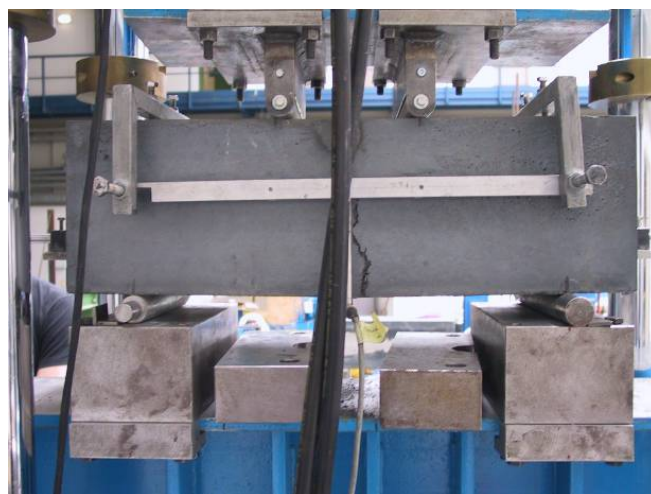

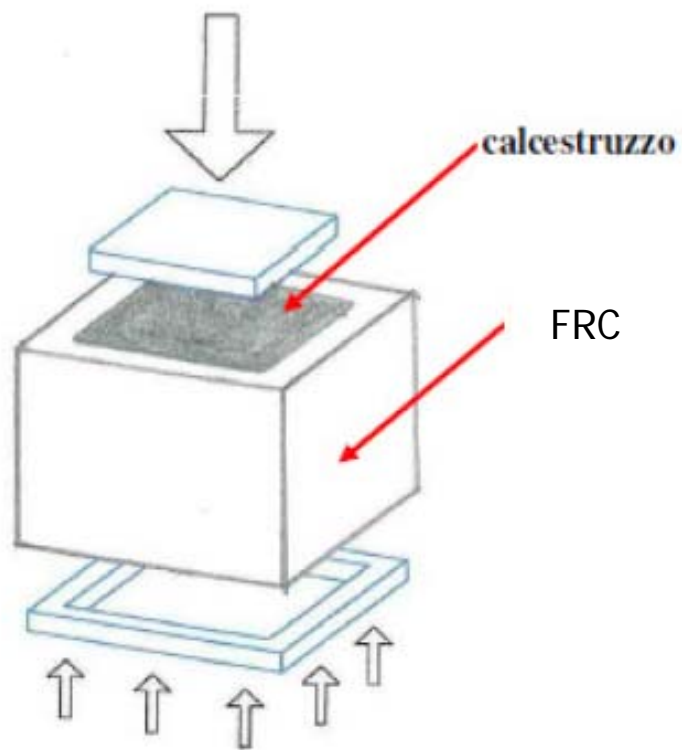

Risultati della prova :

	Provino A	Provino B
carico di rottura :	347,1 kN	535,5 kN
sforzo di taglio medio :	3,86 MPa	5,95 MPa



Preparazione del provino :



Metodo di prova :
compressione sul cubetto cls
con cornice metallica inferiore
a supporto della camicia



Provino al termine della prova
di aderenza a taglio



PROVE COMPLEMENTARI

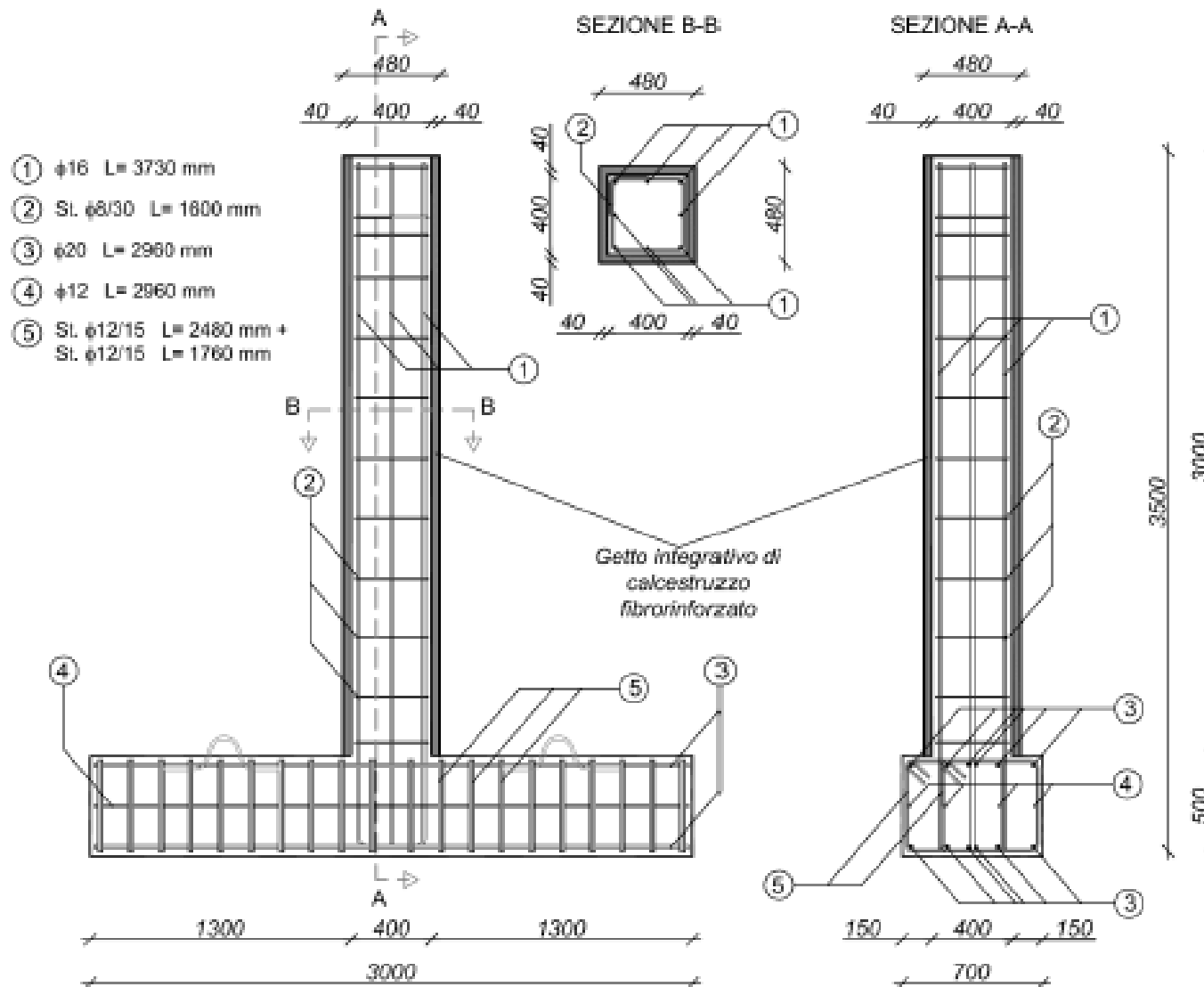

PROVE COMPLEMENTARI



PROVE COMPLEMENTARI

$N = 645 \text{ kN}$
 $T = \pm 72 \text{ kN}$
 $M = \pm 144 \text{ kNm}$



PROVE COMPLEMENTARI

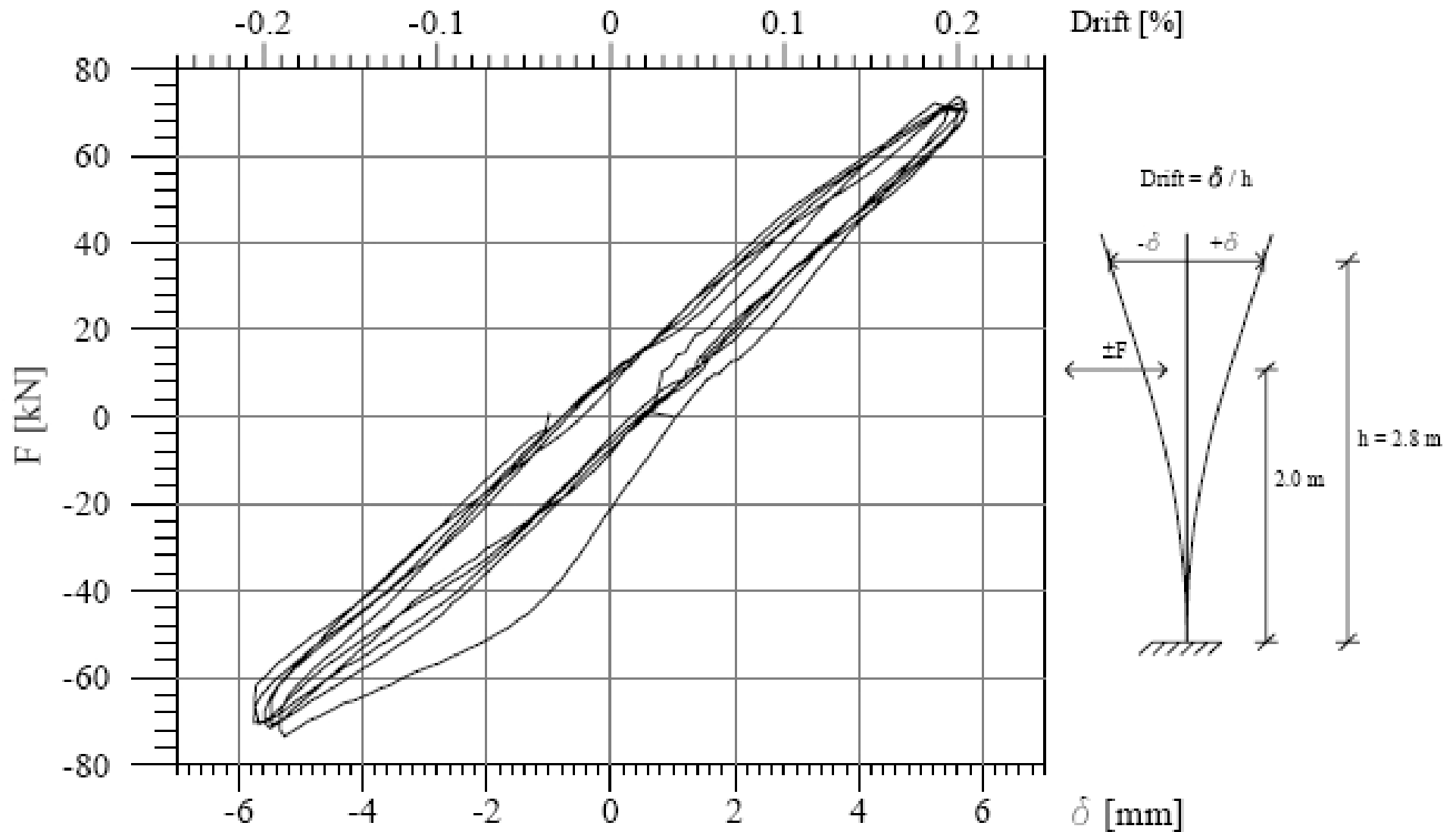

PROVE COMPLEMENTARI



PROVE COMPLEMENTARI

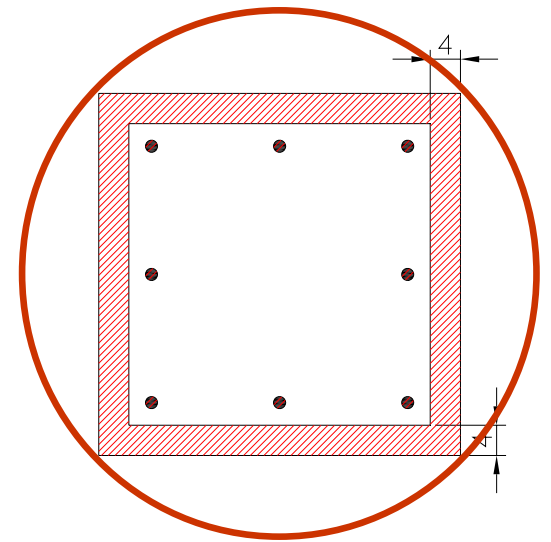
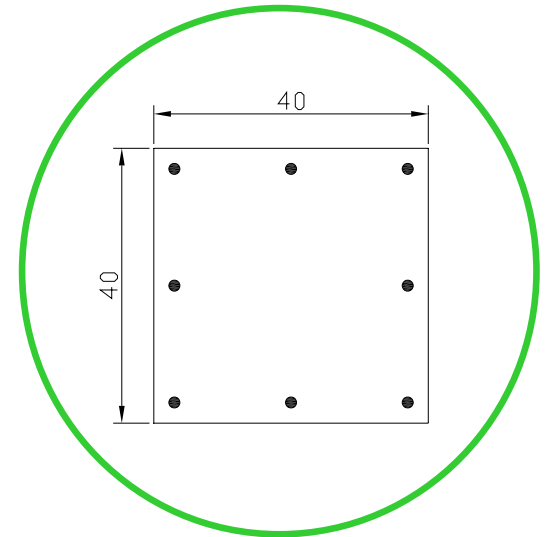
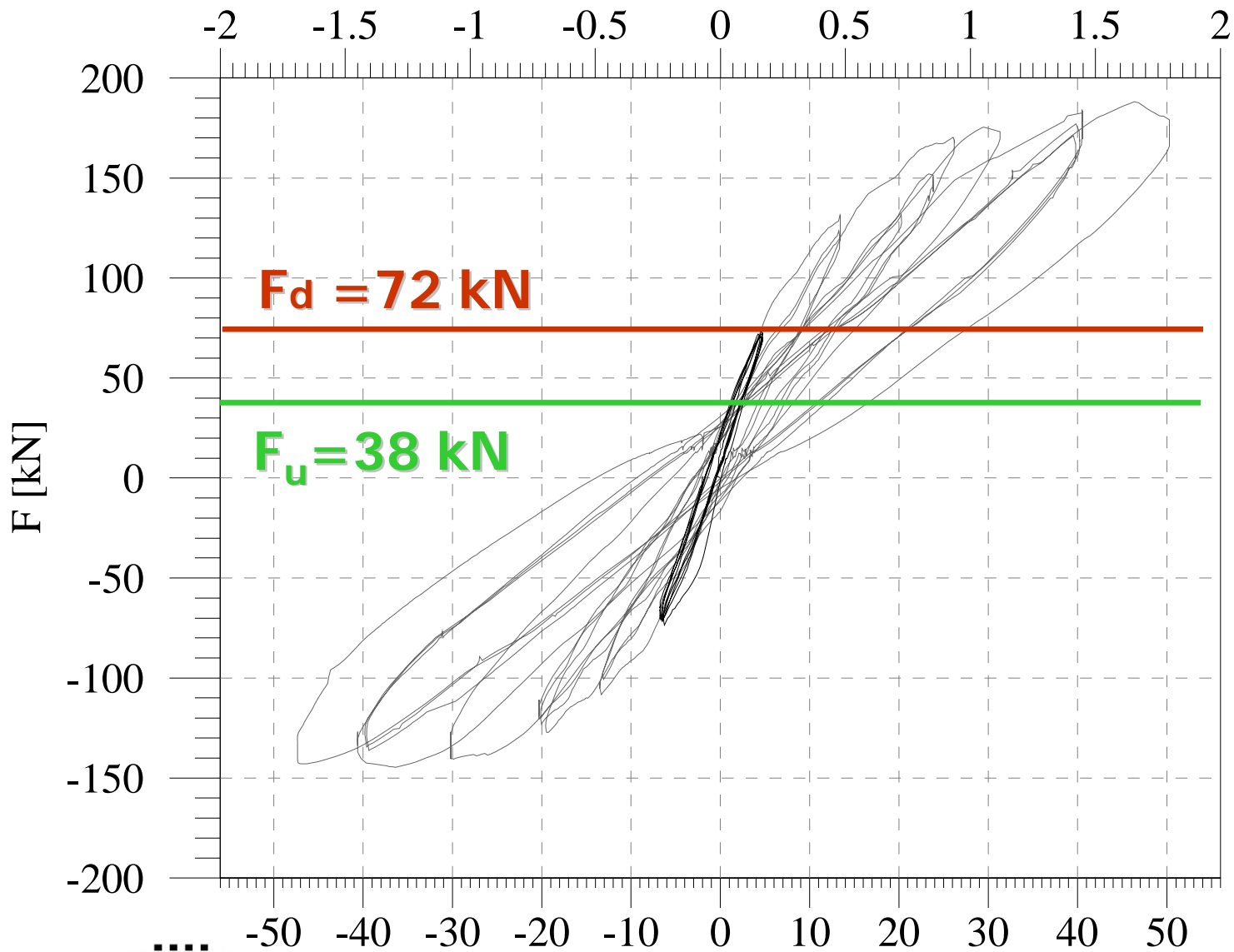

PROVE COMPLEMENTARI



Figura 1 - Geometria del campione di prova



PROVE COMPLEMENTARI

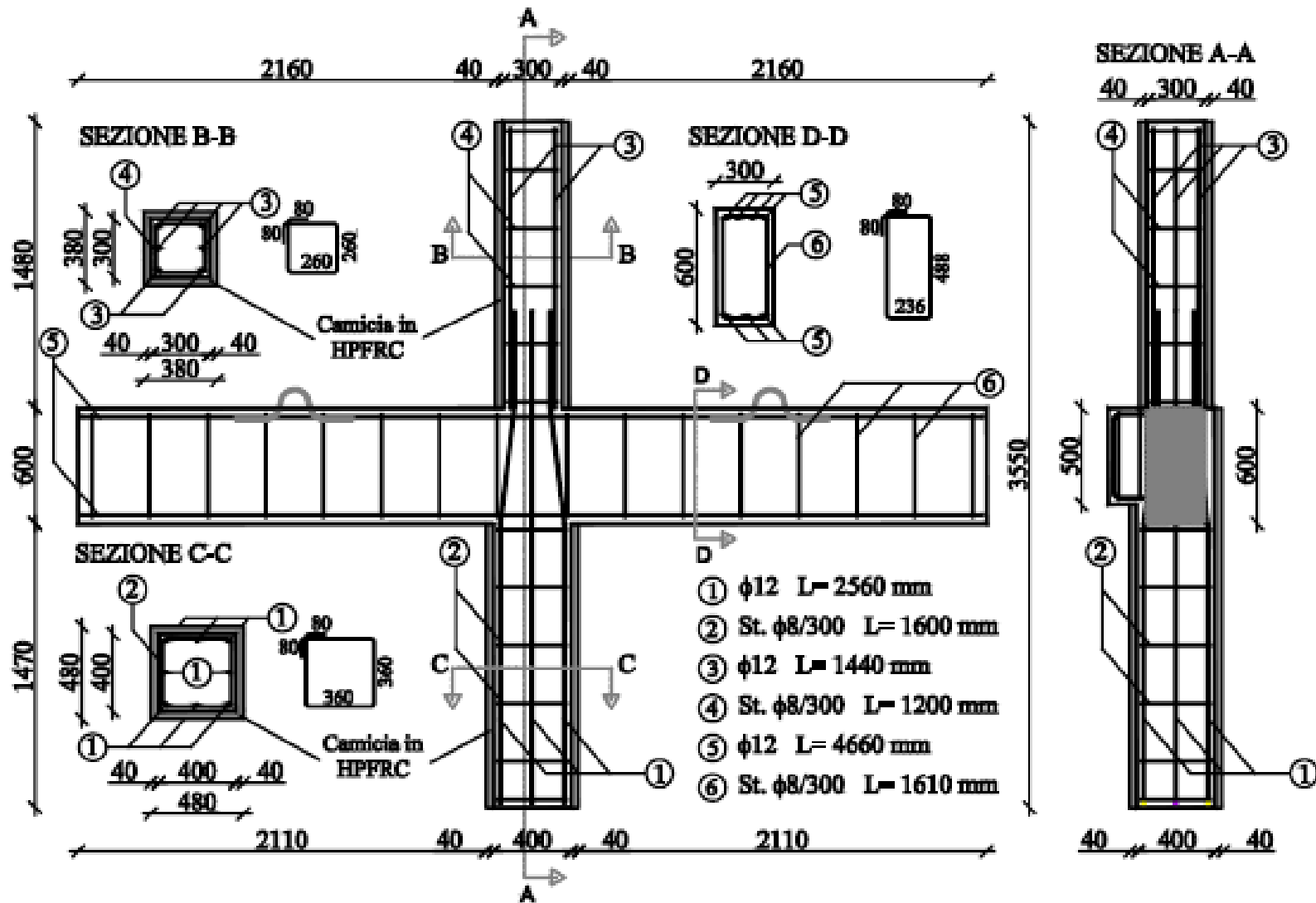

PROVE COMPLEMENTARI



Figura 5 – Schema della strumentazione utilizzata



PROVE COMPLEMENTARI

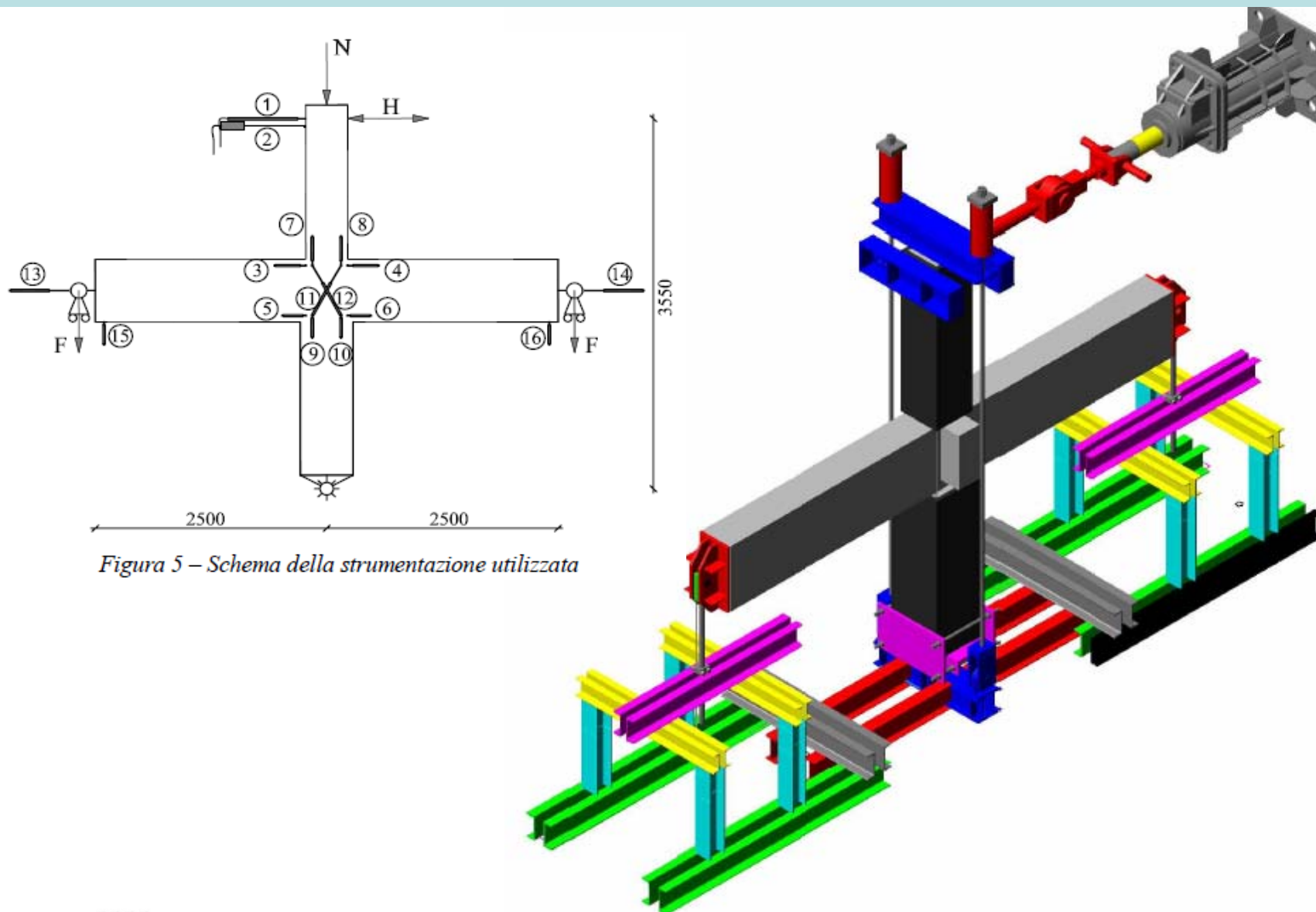

PROVE COMPLEMENTARI

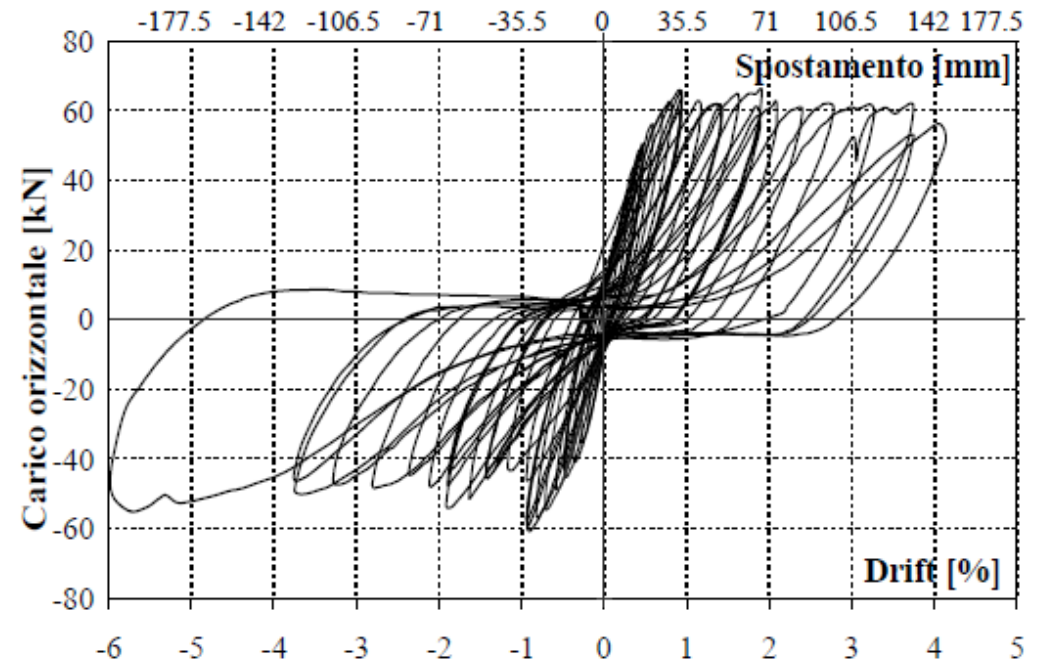
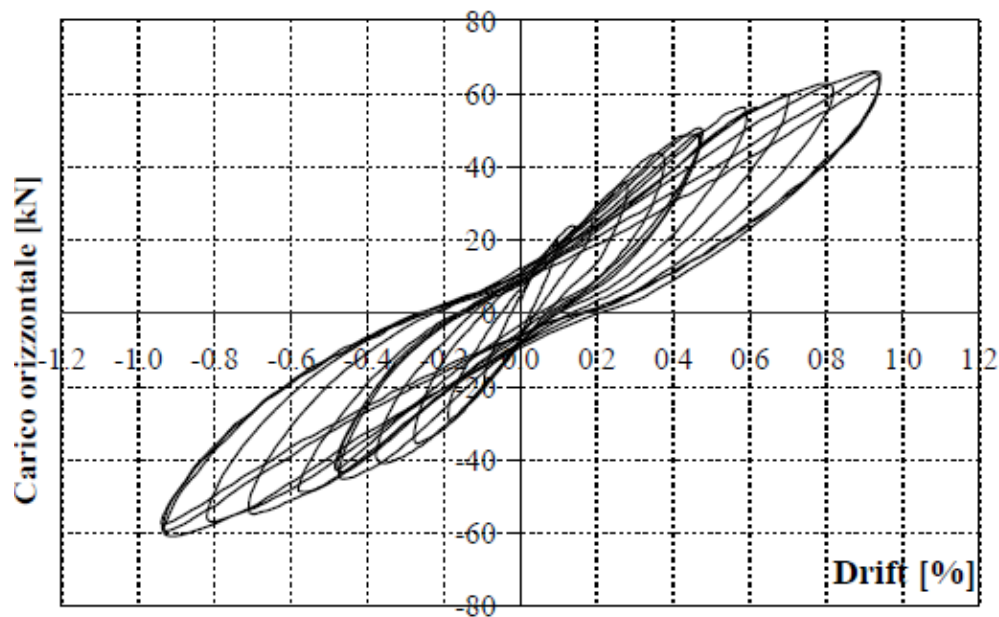

PROVE COMPLEMENTARI



Porosità capillare – Velocità di Carbonatazione

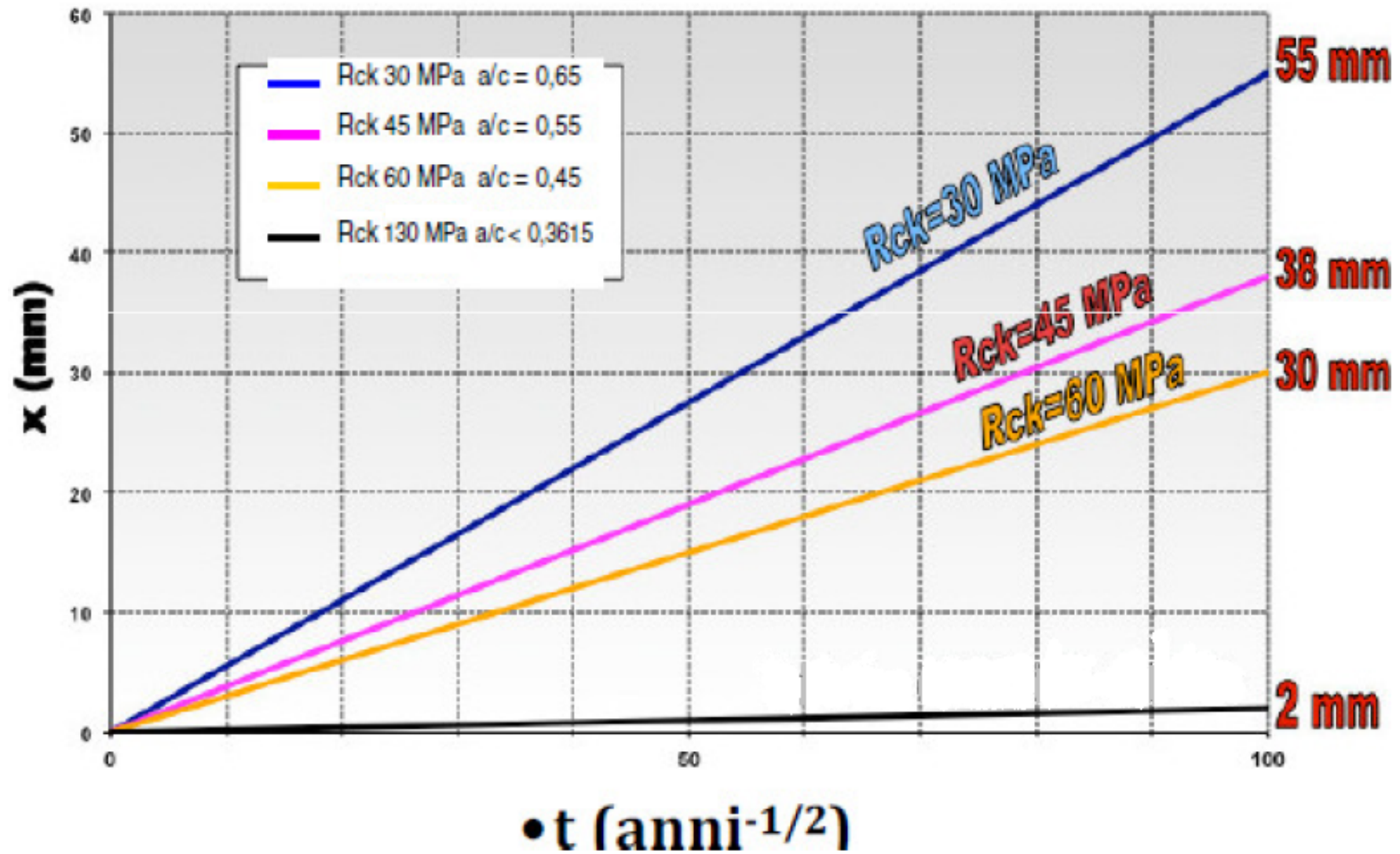



Grazie per l'attenzione

29/10/2012



TECNOCHEM[®]
ITALIANA S.p.A